

**PLAN VIEW**

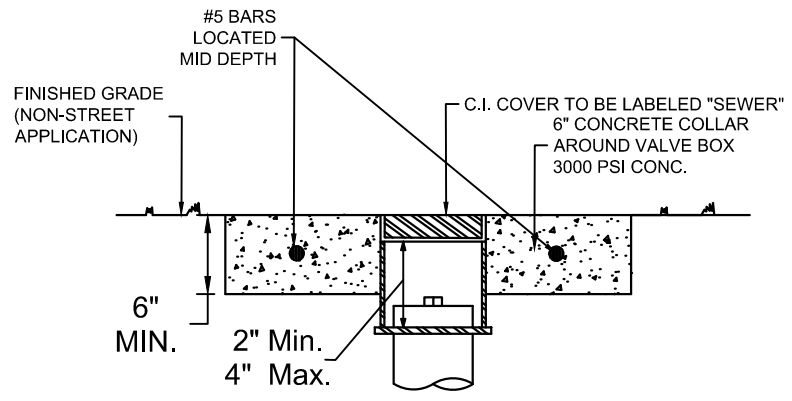

**SECTION B-B**

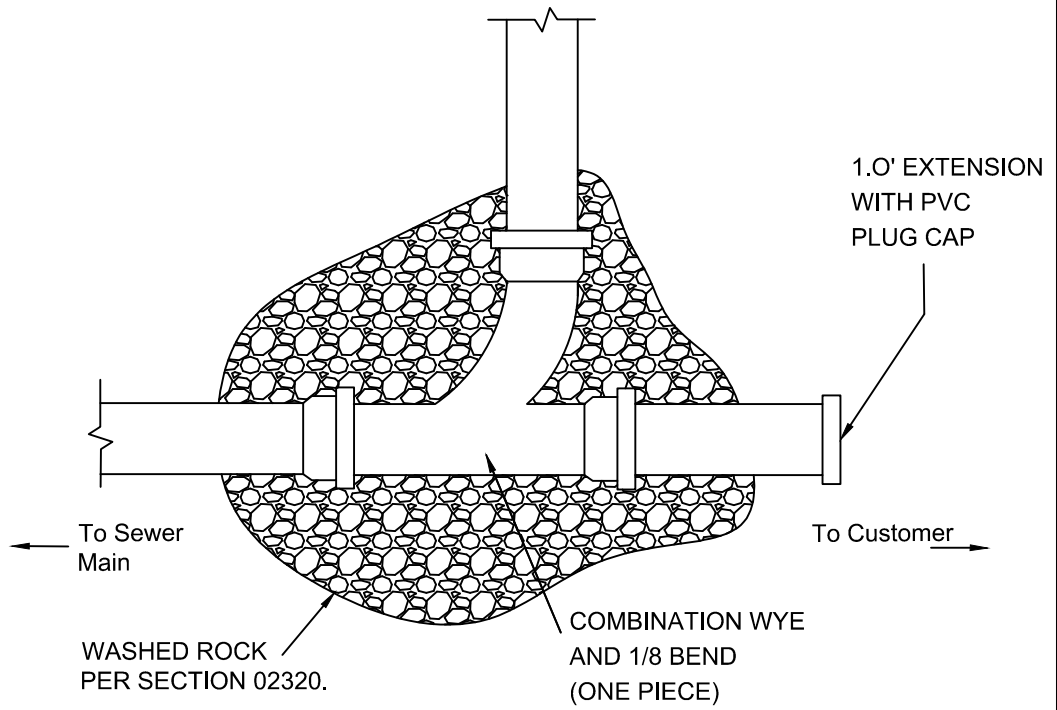

- NOTES:
1. SUBGRADE SHALL BE COMPACTED AS PER SPECIFICATIONS.
  2. VALVE BOX SHALL BE ADJUSTED TO GRADE AFTER FINAL LIFT OR FINAL GRADE IS IN PLACE.
  3. CLEAN VALVE BOX OF ALL DEBRIS DOWN TO THE BOTTOM OF BOX.
  4. REINFORCING STEEL SHALL MEET SPECIFICATIONS.
  5. CONCRETE COLLAR MUST BE ROUND OR SQUARE.

**SCHERTZ**  
 COMMUNITY SERVICE OPPORTUNITY

LATERAL VALVE BOX

TECHNICAL SPECIFICATION SECTION 02534

ENGINEERING AND PUBLIC WORKS	SCALE: N.T.S.	DATE: 5/10/19
DESIGN BY: ENG.	DRAWN BY: BCP	SHEET NO.: 1